

The FG Wilson fully weatherproof sound attenuated CAE enclosures reduce sound levels to comply with the stage 2 levels of the European Community Directive 2000/14/EC which became effective 3 January 2006.

These enclosures incorporate internally mounted exhaust silencers and are of extremely rugged construction in order to withstand the rough handling common on many construction sites. The panel is viewed through a hinged perspex window.

Highly Corrosion Resistant Construction

- ▶ Stainless steel locks
- ▶ Black zinc die cast hinges on gullwing doors tested and proven to withstand extremely corrosive conditions
- ▶ Zinc plated or stainless steel fasteners and hinges
- ▶ Body made from steel components pre-treated with zinc phosphate prior to polyester powder coating

Excellent Access for Maintenance

- ▶ Top hung gullwing doors
- ▶ Hinged and lockable end panels
- ▶ Radiator fill access through radiator end panel
- ▶ Lube oil drain piped to exterior of the canopy

Security and Safety

- ▶ Perspex control panel viewing window in a lockable access door
- ▶ Emergency stop button mounted on canopy exterior
- ▶ End panels secured by internal latches with safety retainer
- ▶ Cooling fan and battery charging alternator fully guarded
- ▶ Fuel fill and battery can only be reached via lockable access doors
- ▶ Exhaust silencing system enclosed for operator safety

Transportability

- ▶ Tested and certified single point lifting facility

Optional Features

- ▶ Lockable vandal proof control panel cover in place of window



P7.5-2S – P22-4 Range



CAE Modular Acoustic Enclosure



Sound Pressure Levels (dba)

		50 Hz at 1500 RPM						60 Hz at 1800 RPM						
		15m (50ft)		7m (23ft)		1m (3ft)		15m (50ft)		7m (23ft)		1m (3ft)		
Generating Set Model	LWA	75% Load	100% Load	75% Load	100% Load	75% Load	100% Load	75% Load	100% Load	75% Load	100% Load	75% Load	100% Load	
3 Phase Models														
P9.5-2*	Prime	-	58.5	59.5	64.5	65.5	72.9	74.1	61.3	62.3	67.3	68.3	76.2	77.2
	Standby	-	58.7	59.8	64.7	65.8	73.1	74.5	61.6	62.8	67.6	68.8	76.5	77.7
P13.5-4	Prime	90	59.7	61.0	65.7	67.0	75.4	76.7	61.3	63.2	67.3	69.2	77.2	79.4
	Standby	90	60.1	61.5	66.1	67.5	75.8	77.2	61.7	64.0	67.7	70.0	77.7	80.2
P18-4	Prime	91	58.6	60.1	64.6	66.1	73.5	74.9	60.7	61.6	66.7	67.6	75.5	76.4
	Standby	91	59.0	60.7	65.0	66.7	73.8	75.5	60.9	62.1	66.9	68.1	75.7	76.8
P22-4	Prime	91	59.5	61.6	65.5	67.6	74.3	76.4	61.1	62.5	67.1	68.5	75.9	77.2
	Standby	91	60.1	62.6	66.1	68.6	74.9	77.5	61.5	63.3	67.5	69.3	76.2	78.0
Single Phase Models														
P7.5-2S*	Prime	-	58.5	59.5	64.5	65.5	72.9	74.1	61.3	62.3	67.3	67.9	75.0	76.1
	Standby	-	58.7	59.8	64.7	65.8	73.1	74.5	61.6	62.8	67.6	68.8	76.5	77.7
P11-4S	Prime	90	59.7	61.0	65.7	67.0	75.4	76.7	61.3	63.2	67.3	69.2	77.2	79.4
	Standby	90	60.1	61.5	66.1	67.5	75.8	77.2	61.7	64.0	67.7	70.0	77.7	80.2
P14-4S	Prime	91	58.6	60.0	64.6	66.0	73.4	74.8	60.7	61.6	66.7	67.6	75.5	76.4
	Standby	91	58.9	60.5	64.9	66.5	73.7	75.3	60.9	62.1	66.9	68.1	75.7	76.8
P16.5-4S	Prime	91	59.2	61.0	65.2	67.0	74.0	75.8	61.1	62.5	67.1	68.5	75.9	77.2
	Standby	91	59.7	61.9	65.7	67.9	74.5	76.8	61.5	63.3	67.5	69.3	76.2	78.0

Levels in accordance with European Noise Directive (2000/14/EC).

*LWA figures not recorded as models are not available in the EU.

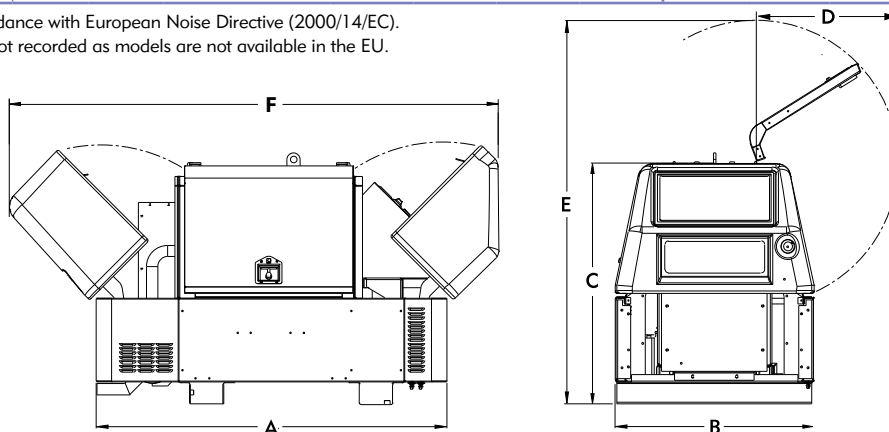

Dimensions and Weights

Generating Set Model	A: mm (in)	B: mm (in)	C: mm (in)	D: mm (in)	E: mm (in)	F: mm (in)	Weight: kg (lb)	Fuel Capacity: l (US gal)
3 Phase Models								
P9.5-2	1593 (62.7)	900 (35.4)	1275 (50.2)	840 (33.1)	1878 (73.9)	2228 (87.7)	494 (1089)	45 (12)
P13.5-4	1593 (62.7)	900 (35.4)	1275 (50.2)	840 (33.1)	1878 (73.9)	2228 (87.7)	580 (1279)	45 (12)
P18-4	1593 (62.7)	900 (35.4)	1275 (50.2)	840 (33.1)	1878 (73.9)	2228 (87.7)	641 (1413)	45 (12)
P22-4	1593 (62.7)	900 (35.4)	1275 (50.2)	840 (33.1)	1878 (73.9)	2228 (87.7)	654 (1442)	45 (12)
Single Phase Models								
P7.5-2S	1593 (62.7)	900 (35.4)	1275 (50.2)	840 (33.1)	1878 (73.9)	2228 (87.7)	494 (1089)	45 (12)
P11-4S	1593 (62.7)	900 (35.4)	1275 (50.2)	840 (33.1)	1878 (73.9)	2228 (87.7)	580 (1279)	45 (12)
P14-4S	1593 (62.7)	900 (35.4)	1275 (50.2)	840 (33.1)	1878 (73.9)	2228 (87.7)	641 (1413)	45 (12)
P16.5-4S	1593 (62.7)	900 (35.4)	1275 (50.2)	840 (33.1)	1878 (73.9)	2228 (87.7)	654 (1442)	45 (12)

Note: Net Weight with lube oil, no coolant, no fuel; Clearance required on all four sides.



FG Wilson has manufacturing facilities in the following locations:

Northern Ireland • Brazil • China • India • USA

With headquarters in Northern Ireland, FG Wilson operates through a Global Dealer Network. To contact your local Sales Office please visit the FG Wilson website at www.FGWilson.com

